

NOTES:

1. FACING TO CONSIST OF PREFABRICATED HOT-DIP GALVANIZED WWF, 4x4-W4.0xW4.0 (100mm x 100mm - 5.7mm DIAMETER) FORMS.
2. ALL FORMS AND STRUTS SHALL BE GALVANIZED.
3. STEEL WIRE AND STRUTS SHALL COMPLY WITH ASTM A82. FABRICATION SHALL MEET ASTM A185.
4. WIRE FORMS SHALL BE HOT-DIP GALVANIZED IN ACCORDANCE WITH ASTM A123/A123M.
5. STEEL STRUTS SHALL BE GALVANIZED (ELECTROPLATED), ASTM A641/A641M.
6. OVERALL LENGTH OF WIRE FORMS IS 10'-0" (3048mm) EFFECTIVE CONSTRUCTED LENGTH IS 9'-8" (2946mm) WITH 2" (50mm) OVERLAP AT ENDS.



Strata Systems, Inc.
 380 Dahlonega Road, Suite 200
 Cumming, Georgia, 30040 USA
 Tel: 770-888-6688
 www.geogrid.com

DESCRIPTION	
Welded-Wire Form 4x4 HDG w4.0xw4.0	
Application: WWF	Design By: SSI
Date: 02/28/15	Drawn By: SSI
Rev #: 001	Scale: NTS

The information provided is a Suggestion only and is supplied by Strata Systems, Inc. free of charge. Determination of the suitability of the information and any Strata product mentioned is the responsibility of the owner or project design engineer of record. The owner or project design engineer of record must assume all risk of loss and damage of any kind arising from use of the information or any product of Strata Systems, Inc.
 copyright 2015 - Strata Systems, Inc., Cumming, Georgia, USA

Sheet
 1
 2

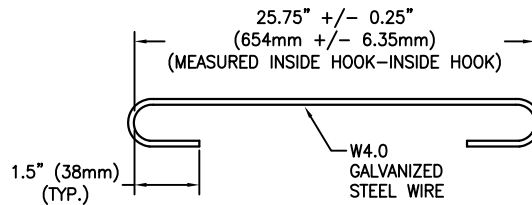

SUPPORT STRUT DETAIL

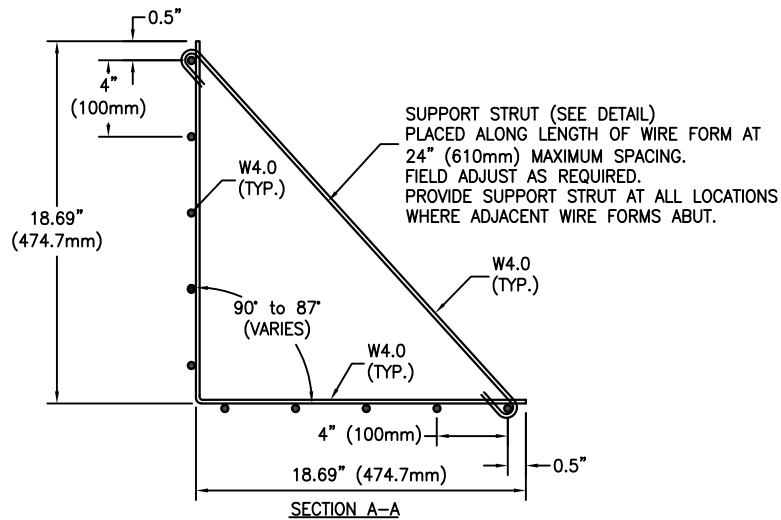

Strata Systems, Inc.
380 Dahlonega Road, Suite 200
Cumming, Georgia, 30040 USA
Tel: 770-888-6688
www.geogrid.com

DESCRIPTION	
Welded-Wire Form 4x4 HDG w4.0xw4.0	
Application: WWF	Design By: SSI
Date: 02/28/15	Drawn By: SSI
Rev #: 001	Scale: NTS

The information provided is a Suggestion only and is supplied by Strata Systems, Inc. free of charge. Determination of the suitability of the information and any Strata product mentioned is the responsibility of the owner or project design engineer of record. The owner or project design engineer of record must assume all risk of loss and damage of any kind arising from use of the information or any product of Strata Systems, Inc.

copyright 2015 - Strata Systems, Inc., Cumming, Georgia, USA

Sheet

2

2